

ROBBENS SYSTEMS®

is a part of FRÄNKISCHE

# Grundfos UPM3 Pump – Not Working

FRÄNKISCHE

FRÄNKISCHE UK

GRUNDFOS  
UPM3 ANTI  
BLOCKING  
CONCEPT



DEBLOCKING  
SOFTWARE

- CONTINUOUSLY  
RESTARTING AFTER  
1.33 SECONDS WITH  
MAX TORQUE OF  
24.8 NCM

DEBLOCKING DEVICE

- MANUAL  
DEBLOCKING DEVICE,  
ACCESS FROM FRONT  
SIDE WITHOUT  
DEMOUNTING THE  
CONTROL BOX

# Grundfos UPM3 – Anti Blocking Concept

The deblocking device consists of an axial moving plunger tightened by an o-ring and pulled back by a spring inside a stainless steel housing that is welded to the rotor can

The de-blocking device is designed for circulators integrated into appliances to give access to the shaft from the front without demounting the control box

By pushing and turning a screw driver Phillips No. 2, the plunger pushes the shaft in axial direction into the circuator, while it can be turned as well.

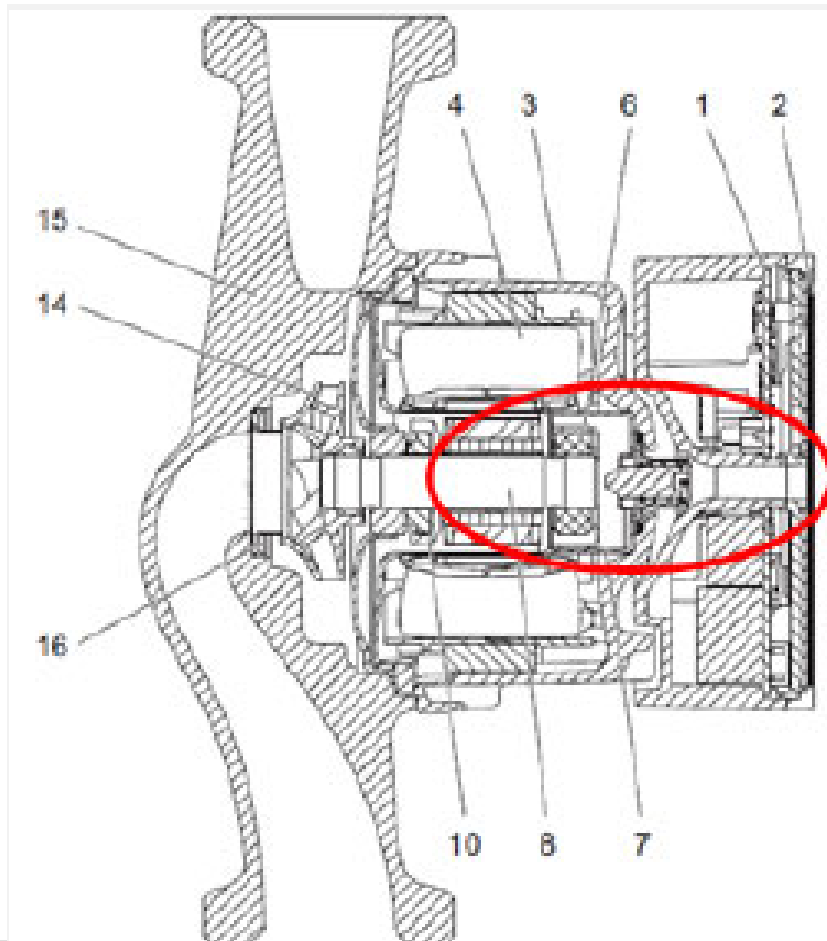

The force is high enough to de-block circulators which are seized by lime e.g. If an appliance is stored for months after being wet tested.

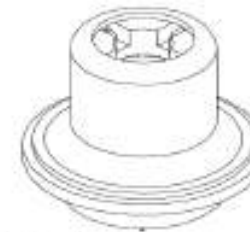

Deblocking device

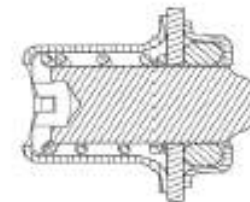

Sectional drawing of deblocking device

Before, during and after the de-blocking, the device is tight and must not release any water

# Double Safety Solution

De-blocking with double safety solution

In case of de-blocking functionality the UPM3 is equipped with a double safety solution:

**THE PUMP MUST BE POWERED DURING THE DE-BLOCKING SEQUENCE**



~ Electronic de-blocking functionality maintaining the maximum starting torque up to 25Ncm

~ Backed by the manual de-blocking device accessible from the front without demounting the control box.

# Manual De-blocking Function

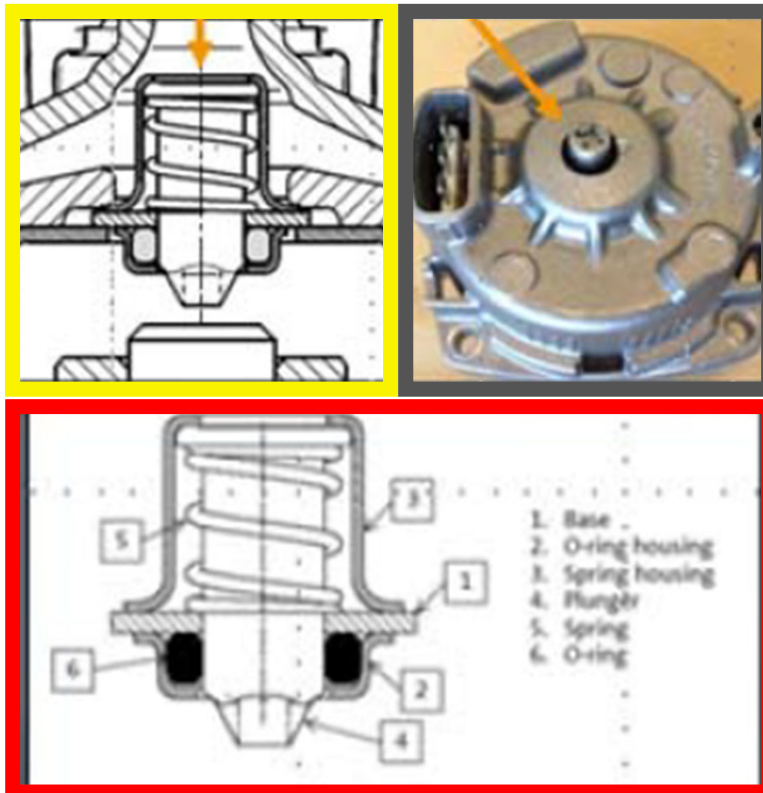

The manual de-blocking device consists of a plunger that axially moves and is sealed in by an o-ring.

The plunger is retracted by a spring which is covered with a stainless steel housing that is welded on top of the rotor can.

The pump should be powered and running whilst attempting to manually clear the blockage.

# Manual De-blocking

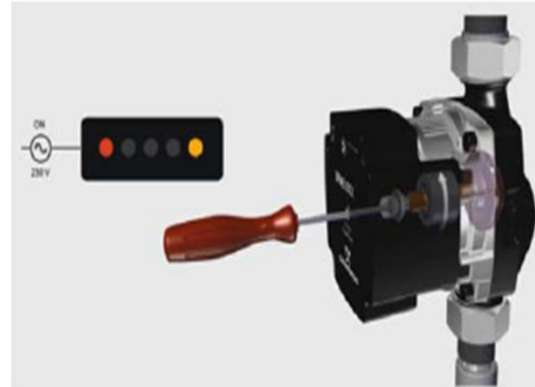
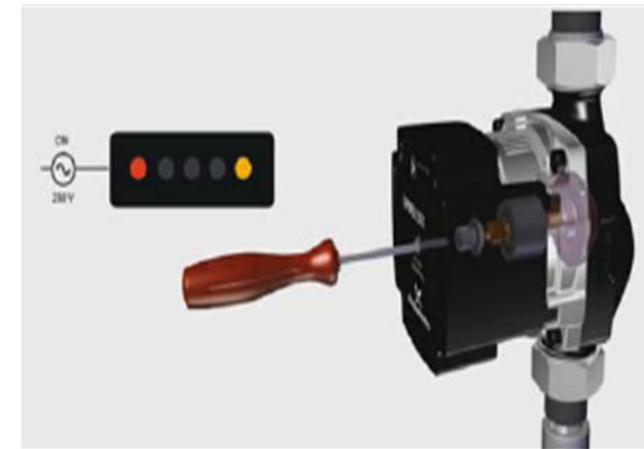

## Fault Findings

FAULT	DISPLAY	SOLUTION
<p>OFF 0 V</p>		<p>A</p> <p>B</p> <p>C</p>
<p>ON 230 V</p>		<p>No.2</p>
<p>ON &lt;160 V</p>		
<p>ON 230 V</p>		

1. CHECK POWER
2. FOLLOW DE-BLOCKING PROCEDURE
3. CHECK VOLTAGE
4. REPLACEMENT PUMP REQUIRED

A photograph of the LED's is required for support – email to [sales@robbens.co.uk](mailto:sales@robbens.co.uk)



# Fault Finding

**WARNING –**  
BEFORE STARTING  
WORK AT THE  
PUMP, SWITCH  
OFF THE POWER  
SUPPLY

Fault	Cause	Remedy
1. Pump is not running. No power supply.	• System is switched off.	Check the system controller.
	• A fuse in the installation is blown.	Replace the fuse.
	• The circuit breaker has tripped.	Check the power connection and switch on the circuit breaker.
	• Power supply failure.	Check the power supply.
2. Pump is not running. Normal power supply.	• Controller is switched off.	Check the controller and its settings.
	• Pump is blocked by impurities.	Remove impurities. Unblock the pump from the front of the control box with a screwdriver.
	• Pump is defective.	Replace the pump.
3. Pump runs at maximum speed and cannot be controlled.	• No signal from signal cable.	Check if the cable is connected to the controller. If it is, replace the cable.
4. Noise in the system.	• Air in the system.	Vent the system.
	• Differential pressure is too high.	Reduce the pump performance at the pump or external controller.
5. Noise in the pump.	• Air in the pump.	Let the pump run. The pump vents itself over time.
	• Inlet pressure is too low.	Increase the system pressure or check the air volume in the expansion tank, if installed.
6. Insufficient flow.	• Pump performance is too low.	Check the external controller and the pump settings.
	• Hydraulic system is closed or system pressure is insufficient.	Check the non-return valve and filter. Increase the system pressure.
7. Pump LED5 is on. Pump tries to restart every 1.5 sec.	• Rotor shaft is blocked.	Deblock the rotor shaft by pushing it with a screwdriver from the front of the pump.
8. Pump LED4 is on. Pump is running.	• Supply voltage is too low.	Check the supply voltage.
9. Pump LED3 is on. Pump stops.	• Supply voltage is too low.	• Check the supply voltage.
	• Serious failure.	• Exchange the pump.

## WARNING –

ENSURE THAT THE  
POWER CANNOT  
BE SWITCHED ON  
ACCIDENTLY

## WARNING –

THE CAPACITORS  
WILL BE LIVE FOR  
UP TO 30  
SECONDS AFTER  
THE POWER  
SUPPLY HAS BEEN  
SWITCHED OFF

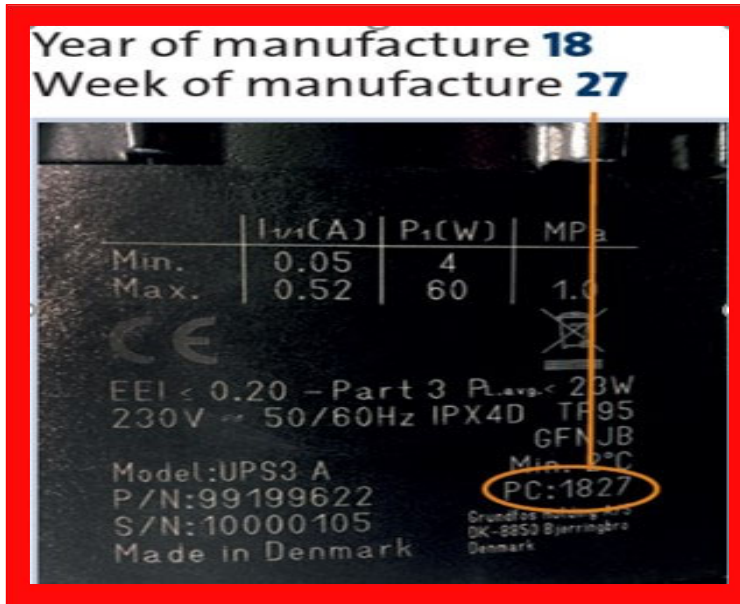

Grundfos UPM3 pumps are warranted for 24 months from the date of supply or 30 months from the date of manufacture.

See image to left for manufacturing date.

The manufacture date can be found on the data plate on the pump head under the PC number.

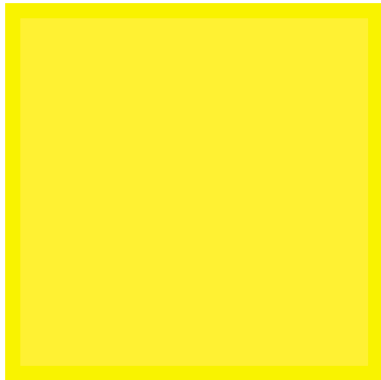

EG – PC1827 is as follows –  
18 – Year of manufacture  
27 – week of manufacture





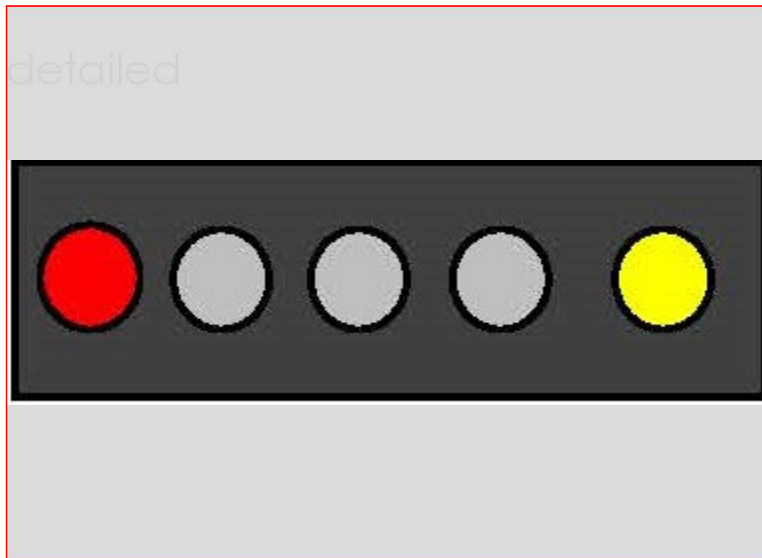

Only the above light sequence is covered on this page

If the pump is within warranty period as previously then –

- Talk customer through de-blocking process.
- Refer customer to their plumber.
- If plumber has no success refer them to Grundfos – Telephone 01942 263628.
- The caller will be transferred to the Workshop Team.

Grundfos Workshop Team will –

- Go through simple deblocking process with customer.
- Recommend back to plumber or if it is the plumber, continue with process.
- Grundfos will send out a new pump under warranty to the customer.
- Grundfos will arrange to collect the faulty pump from customer via TNT